

- Nozzle Diffuser
Model: TND-AA • Aluminum • High Capacity

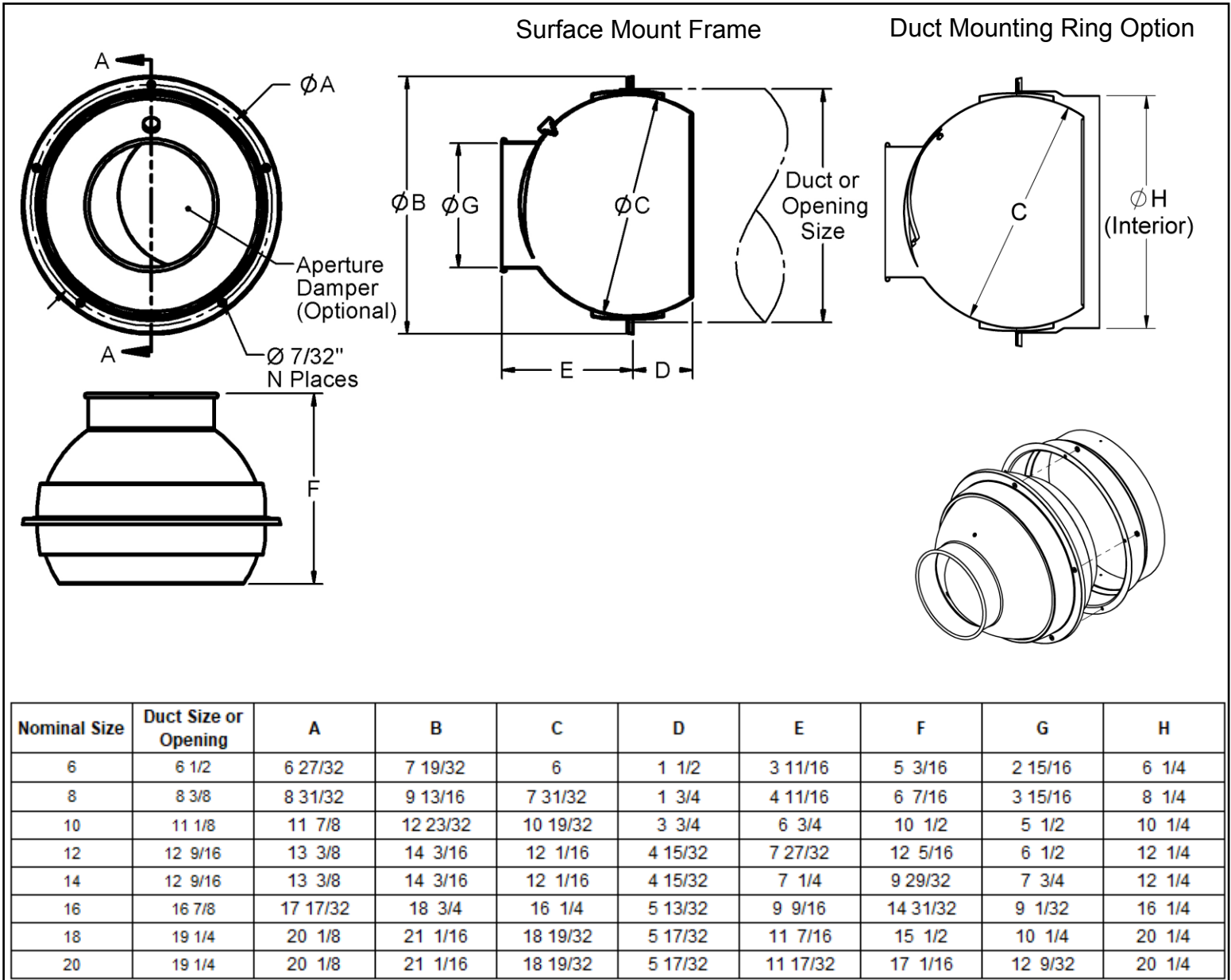

- Designed to handle large air capacity requirements and provide concentrated long throws.
- Round nozzles are adjustable within mounting ring to 38 °.
Duct or hard surface mountable.
- Well suited for installations where the conditioned space is large, and where it is impractical to bring the duct work close to the occupants. Examples being shopping malls, coliseums, field houses, air terminals, factories and warehouses.
- Optional aperture volume damper accessible on face of nozzle.
- Extruded aluminum / aluminum construction.
- Available in #01 Aluminum, #26 White or #84 Black